

Put one of the side module of the cabinet on a suitable floor.

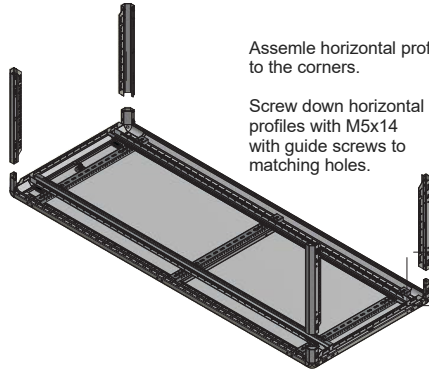

Assemble horizontal profiles to the corners.

Screw down horizontal profiles with M5x14 with guide screws to matching holes.

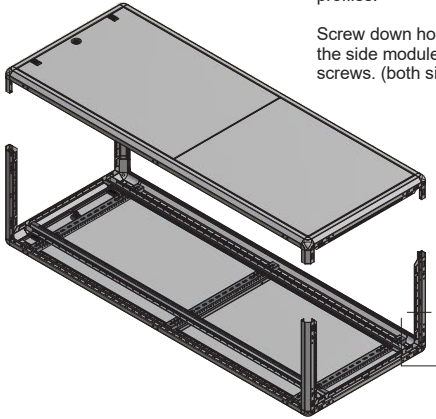
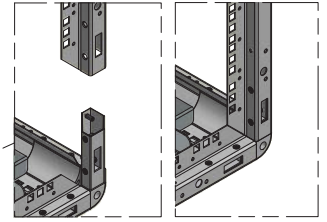

Mount other side module of the cabinet on screwed horizontal profiles.

Screw down horizontal profiles to the side module with M5x14 guide screws. (both sides)

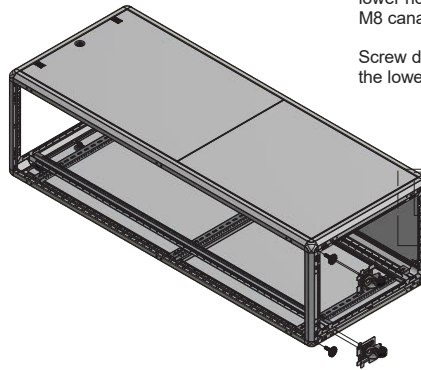
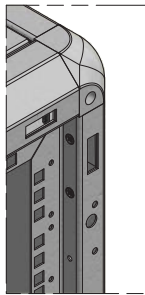

Screw down casters to the lower horizontal profiles with M8 canal screw and M8 nut from 4 points.

Screw down pinion feet to the lower corner parts.

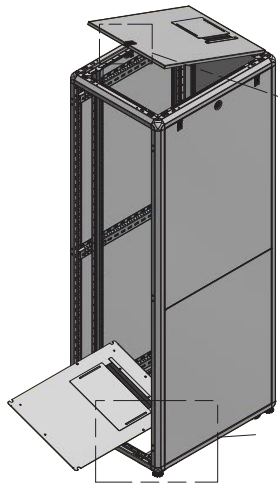
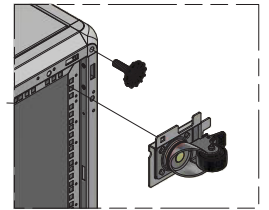

Stand the cabinet up and put panel to the top.

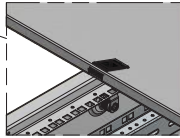

Replace the bottom plate and screw it down with the M6x15 YBS screws to the cage nuts.

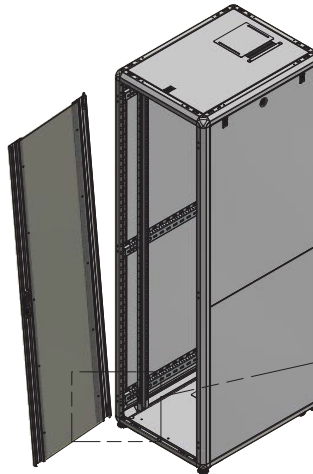
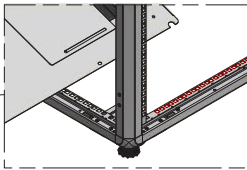

Replace plastic hinge sockets to the top and bottom profiles as shown on Picture.

Replace the front door bottom hinge into the plastic hinge socket then replace the upper hinge with a help of hammer.

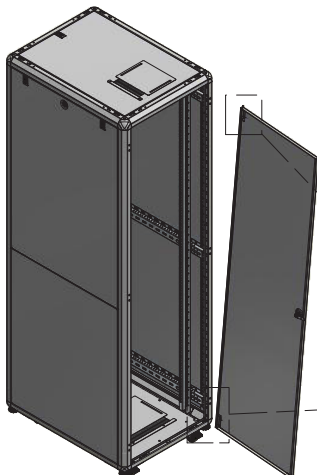
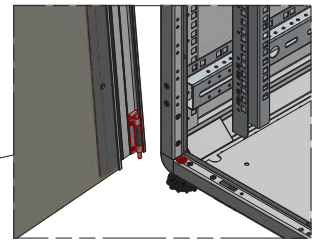

Replace plastic hinge sockets to the top and bottom profiles as shown on Picture.

Replace the back door bottom hinge into the plastic hinge socket then replace the upper hinge with a help of hammer.

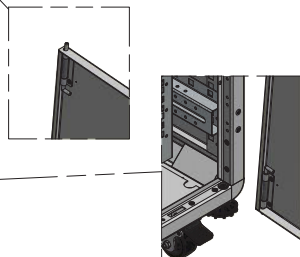

Final

